

Assay.	Nitrogen.	Chlorine.
Found	5.61%	15.05%
Calc. for $C_{15}H_{20}O_2N_2Cl_2Br_2$	5.70%	14.46%

SUMMARY.

- (1) Di- β -bromallylamino ethyl *p*-amino benzoate was prepared.
- (2) Aqueous solutions of the dihydrochloride are too acid for anesthetic tests. The solutions are incapable of buffering without precipitating the base from solution.

BIBLIOGRAPHY.

- (1) U. S. Patent 1,388,573.
- (2) *J. A. C. S.*, 50 (1928), 145.

RESEARCH DEPARTMENT OF THE CHEMICAL AND PHARMACEUTICAL LABORATORIES,
E. R. SQUIBB AND SONS, BROOKLYN, N. Y.

PHYSICS IN PHARMACY.

BY JOHN URI LLOYD, WOLFGANG OSTWALD AND HANS ERBRING.

(Continued from page 221, March issue.)

In *Fig. 13*, for example, quantities of absorbed, saturated solutions of KCl, BaCl₂ and FeCl₃, under identical experimental conditions, are recorded. With increase in valence, there is increase of absorption. Furthermore, FeCl₃ in dilute solution is strongly hydrolyzed. The retained liquid volume must vary, not only with the concentration of the solutions, but also with the electrocapillary effects of the different ions,¹ and finally, with the influence of the dissolved substance on the state of swelling of the cellulose fibres.

10. Influence of Concentration and Temperature.

TABLE IX.—INFLUENCE OF CONCENTRATION.

System: FeCl ₃ , concentrations as below, vs. Water. <i>d</i> = 1.5 mm. Paper dry at start.	Duration, Hours.	FeCl ₃ —Increase, Mm.	H ₂ O—Decrease, Mm.	Total Difference, Mm.
45% FeCl ₃ Solution.				
	2	0.5	1.0	1.5
	5	1.0	2.5	3.5
	20	2.0	4.0	6.0
	40	2.6	5.0	7.6
	72	3.0	6.5	9.5
23% FeCl ₃ Solution.				
	2	...	0.9	0.9
	4	0.5	2.0	2.5
	20	1.2	3.0	4.2
	40	2.0	4.0	6.0
	70	2.2	4.0	6.2

¹ We mention here the phenomena of the so-called "abnormal osmosis," cf. a résumé by K. Söllner, *Zschr. f. Elektrochemie*, 36 (1930), 234.

12% FeCl₃ Solution.

10	0.2	1.5	1.7
20	0.5	2.2	2.7
40	0.6	2.5	3.1
60	0.7	3.0	3.7
70	1.0	3.2	4.2

TABLE X.—INFLUENCE OF CONCENTRATION.

System: Urea Solutions vs. Water; $d = 12$ cm. Paper dry at start.

Duration, Hours.	Urea—Increase, Mm.	H ₂ O—Decrease, Mm.	Total Difference, Mm.
50% Urea Solution.			
10	1.4	2.0	3.4
20	2.2	3.5	5.7
40	3.2	4.5	7.7
80	3.0	5.0	8.0
4 wks.	1.0	3.0	4.0
25% Urea Solution.			
10	0.5	0.5	1.0
20	1.0	2.0	3.0
40	1.5	2.5	4.0
80	1.5	3.5	5.0
12.5% Urea Solution.			
10	0.2	0.5	0.7
20	0.5	1.5	2.0
40	0.5	2.5	3.0
80	0.5	3.5	4.0

The influence of *Concentration* is shown in *Tables IX and X*, and in *Figs. 14 and 15* for Ferric Chloride and Urea. In the figures, the individual curves denote for the several concentrations, increases of level in cylinder S after each period of time, e. g., 10, 20, 40 and 70 hours. These curves are, as it were, cross sections taken at each period of time, through the speed curves of the increase of level.

Only the sections through the ascending branch of the curves up to the maximum are here of interest.

With FeCl₃ (see *Fig. 14*), a group of curves is obtained, the lowermost of which, corresponding to the shortest period of time, differs very little from a straight line, while the curves obtained by sections at later periods of time have a faintly S-shaped course. It should be remembered in this connection, that FeCl₃, on account of its hydrolysis in solutions, represents a relatively complicated system.

Urea, on the contrary, shows much simpler curves, the two lowermost of which

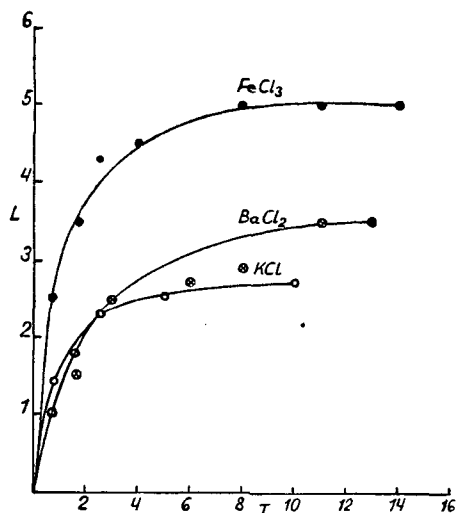

Fig. 13.—L, Quantity of liquid held back by paper, in mm.; T, Time in days.

differ but little from a straight line. All deviations, however, are in the sense of curvature *convex* to the axis of concentration. Still, this mode of deviation and curvature is characteristic for most of the concentration functions of the directly measured osmotic pressure of concentrated solutions, whether molecular-disperse or colloidal.¹

Influence of Temperature.—To study the influence of temperature, experiments were carried out under identical conditions, except that the temperature in one case was 20° C. (room temperature), in the other 50° C. (Air-thermostat).

TABLE XI.

System: FeCl ₃ (saturated), vs. Water. $d = 7$ cm. Paper dry at start.		
Duration.	Increase of Level at 20°.	Increase of Level at 50°.
4 hrs.	0.8 mm.	0.9 mm.
30 hrs.	1.4 mm.	1.6 mm.
50 hrs.	2.1 mm.	2.5 mm.

Table XI shows a slightly higher increase of level at 50° than at 20°.

11. *Isothermal Distillation.*—We mentioned before, that part of the liquid evaporates and condenses along the walls of the tubes. This suggested the possibility that water, having a higher vapor pressure, may be transferred into cylinder S through isothermal distillation. No doubt such a process takes place; but we can show that isothermal distillation, alone, is not sufficient to produce the Effect here described.

In order to test out this possibility, experiments were conducted with identical arrangement of apparatus, except that *filter paper was not used*. If in the course of time differences of level develop under these conditions, they can be explained only through differences of vapor pressure. Our experiments (see Table XII) have shown that after about 3 days, a small difference of level in the expected direction, indeed, appears. This difference, however, is incomparably smaller than the experiments with filter paper have shown, in which, in a shorter time, a value 20 times as much has often been obtained.

TABLE XII.

System: FeCl ₃ (saturated), vs. Water.				
Duration.	FeCl ₃ Increase.	H ₂ O Decrease.	Total Difference.	Length of d .
2 hrs.	4 cm.
20 hrs.	
72 hrs.	0.3 mm.	1.0 mm.	1.3 mm.	
5 days	0.5 mm.	1.5 mm.	2.0 mm.	
20 hrs.	0.2 mm.	0.2 mm.	0.4 mm.	1.5
48 hrs.	0.7 mm.	0.7 mm.	1.4 mm.	
60 hrs.	0.7 mm.	0.7 mm.	1.4 mm.	
5 days	1.0 mm.	1.0 mm.	2.0 mm.	

These results show that the differences in vapor pressure produce our Effect on a very small scale, hence the velocity of isothermal distillation is far too small to account for the relative magnitude of our Effect.

¹ Cf. Wo. Ostwald, *Kolloid-Z.*, 49 (1929), 62, 80; 56 (1931), 263; *Z. physiol. Chem.-A*, 159 (1932), 375.

Surface Tension.—Motions in capillary systems have been linked with differences in surface tension since Dutochet, and more recently, since I. Traube and others. The capillary rise in filter paper is of course a result of surface tension, and will vary in height or speed, according to the magnitude of the tensions of the two liquids. As soon as the 2 liquids have met in the filter paper, however, there can no longer be any difference of surface tension between them. There may remain differences in *wetting power*, which would lead to the displacement of the pure solvent by the better wetting solution. Thus a movement of liquids might arise which, however, would stop at once when the capillaries of the filter paper are saturated with the better wetting, dissolved substance.

In order to examine the extreme case of such a wetting current, a very dilute (0.05%) soap solution was placed against pure water. In this case, the difference of the two surface tensions is extremely great, at any rate considerably greater than, *e. g.*, in the case of FeCl_3 *vs.* water. Also, the wetting power of soap solution is naturally greater than that of pure water. The effect produced is shown in *Table XIII*.

TABLE XIII.

System: Sodium Palmitate (0.05%) *vs.* Water.

Duration.	Soap Solution, Decrease.	Water, Increase.
24 hrs.	1.0 mm.	...
46 hrs.	1.0 mm.	...
70 hrs.	1.5 mm.	1.0 mm.
8 days	1.5 mm.	1.0 mm.
10 days	1.5 mm.	1.2 mm.
15 days	1.5 mm.	1.2 mm.

A transfer of soap solution to water is distinctly noted; but again the Effect is of considerably smaller magnitude than in the case of FeCl_3 *vs.* H_2O , notwithstanding the fact that the difference in surface tensions and wetting powers is much greater in the former than in the latter. Besides, the movement ceases after about 3 days, which agrees with theoretical prediction.

Thus the source of energy causing the Effect described, cannot reside in differences of surface tension and of wetting power.

III. THEORY OF THE EFFECT.

Before giving the theoretical explanation of the Effect, we will summarize once more the principal phenomena graphically, as it is done in *Fig. 16*. The Effect, as to time, takes place in three parts (I, II, III). To these, strictly speaking, should be added a "prelude," consisting in the preliminary capillary rise of both liquids.

In *Fig. 16*, *A* shows the rise in the salt tube, or the difference of level of both liquids during the experiment. *D* shows the location, resp., the migration of the diffusion zone between salt solution and water during the process. This migration within the filter paper is represented somewhat more plainly in *C*. Finally, *D* shows the change of the average difference of densities of the liquids to the right and the left of the filter paper during the process. This difference of density is only estimated from the intensity of coloration, *e. g.*, in the experiments with FeCl_3 ; hence the curve cannot be considered of quantitative value, although it correctly represents differences of actual observation.

With the aid of this synoptical *Fig. 16*, we present the following:

THEORY OF THE EFFECT.

Preliminary Process: Water as well as salt solution, rises in the siphon as a result of surface tension.¹ The liquids meet in the filter paper.

In our experiments, the salt solution was given an advantage in order to enable the two liquids to meet at about the middle of the strip (cf. *Fig. 16, C-I*). This is

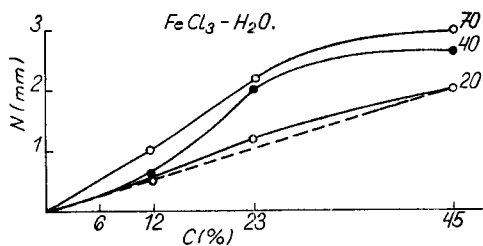

Fig. 14.—C, Concentration in %; N, Increase of level in mm.; Concentration curves after 20, 40 and 70 hrs.

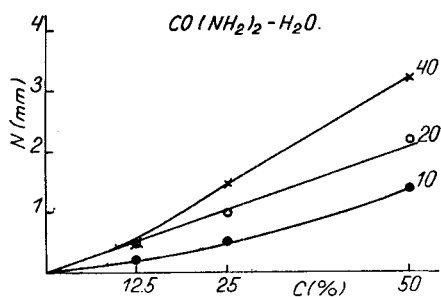

Fig. 15.—C, Concentration in %; N, Increase of level in mm.; Concentration curves after 10, 20 and 40 hrs.

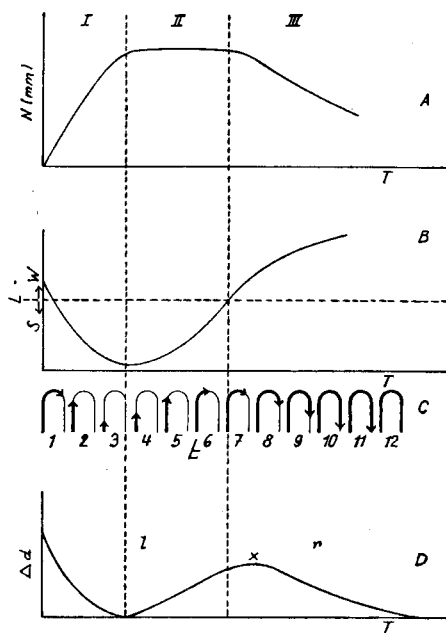

Fig. 16.—Scheme A: N, Rise in the salt tube, or difference of level of both liquids; T, Time. Scheme B: L, Position of zone limit of diffusion; W, Water tube; S, Salt tube; T, Time. Scheme C: L, Position of zone limits of diffusion. Scheme D: Δd , Average difference of densities of liquids to left and right in filter paper; l, Left tube heavier; r, Right tube heavier; T, Time.

the starting condition, at which, in our experience, the Effect manifests itself most strongly.

I. The *First Divisional Effect* consists in a steep rise of liquid in the salt tube, *i. e.*, a sharp increase in the difference of level, with which is connected a sinking of the interface salt-solution-water in the salt tube (easily recognized with colored salts), and finally a corresponding decrease of the differences of weights of the liquid cylinders in both siphon tubes (cf. *Fig. 16, I-D*).

¹ The remarkable phenomena of capillary rise of solutions in filter paper have been pointed out by the senior author, more than 50 years ago. Proc. A. PH. A., 1879-1885; reprinted in *Kolloidchem. Beihefte*, 8 (1916), 174.

At least three sources of energy may be named as bringing about this movement of liquids. First, the process is evidently that of a hydrostatic siphon effect. When we connect two liquids of different densities by means of a siphon, as depicted in *Fig. 17*, hydrostatic equilibrium will exist only when the products of height times density are equal in both arms of the siphon. In the arrangement shown in *Fig. 17a* (adopted in our experiment), the weights of the liquid columns in both branches are evidently not equal at the start. Therefore, liquid will move in the direction of the arrow, from water to salt solution, which continues until the two liquid columns, now of different lengths, have again attained equal weights (cf. *Fig. 17b*). In contrast with an ordinary siphon with large cross section (*e. g.*, a glass tube), the hydrostatic equilibrium in our experiment does not take place instantaneously, but requires, for example, up to about 10 days' time. This is not

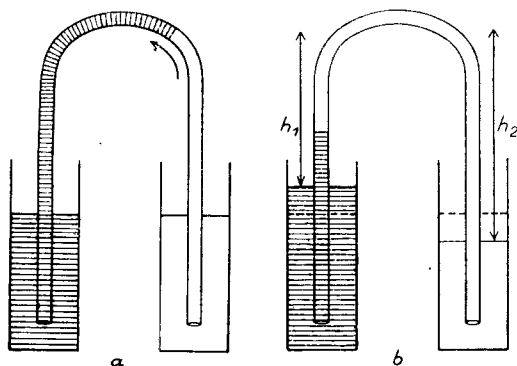

Fig. 17a.

Fig. 17b.

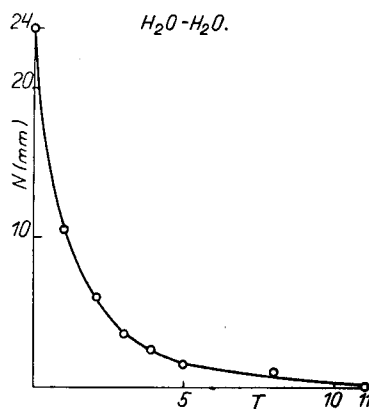

Fig. 18.—N, Difference of level in mm.; T, Time in days.

surprising when we consider the fact that, according to Hagen-Poiseuille's law, the velocity of flow decreases exceedingly fast with the diameter of the capillary tubes; for circular pipes in the ratio of r^4 , *i. e.*, the fourth power of the radius. Besides, we have in filter paper very irregular capillary spaces, which compel the current to follow detours.

The slowness of a purely hydrostatic equalization in filter paper is well illustrated by the experiment of *Fig. 18*. Hydrostatic equalization was observed in a system containing water on both sides, but in which a difference of level of 24 mm. was given to it at the start. About 11 days were required for the termination of this purely hydrostatic equalization.

Thus, one explanation of the 1st divisional effect which readily suggests itself, would consider the rise as a simple hydrostatic *Capillary Siphon Effect*.

However, this explanation does not exhaustively describe the dynamics of the process. Another source of energy exists, for it is evident that within a period of 11 days of experimentation, with the system employed, *Diffusion* must also become effective. In the capillary siphon we have a continuous passage between salt solution and water, which presents the preliminary conditions for diffusion to manifest itself. The diffusion of the salt molecules takes place in opposite direction to that

of the water current, which from hydrostatic causes, flows from the water tube to the salt tube. Although this current overcomes the motion of diffusion, as is evidenced by the retrogression of the joint diffusion surface, diffusion will nevertheless not be completely inactive. It will rather act always in the direction of increasing the weight in the salt tube, *i. e.*, constantly supporting the hydrostatic effect. Hence, the mechanism of liquid movements during the first divisional effect, is a combination of a purely hydrostatic effect (represented by the initial condition), and a simultaneous secondary hydrostatic effect produced by diffusion. Thus the

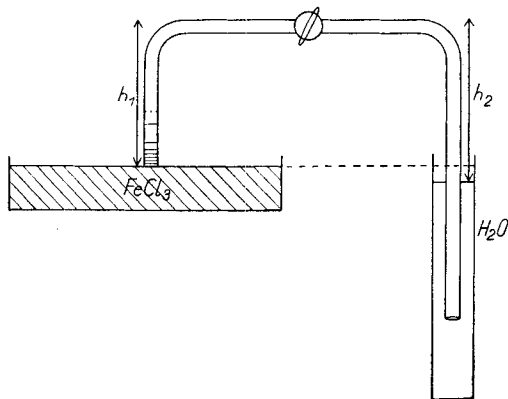

Fig. 19.

strip of paper acts at first as a "capillary siphon," as well as a *Diffusion Siphon*.

The mode of action of such a "Diffusion Siphon," can very well be demonstrated by the following arrangement of apparatus, to which E. Manegold—Göttingen kindly called our attention.¹ *Fig. 19*. A bent capillary tube dips at the left end directly beneath the surface of a salt solution contained in a wide dish, at the right into water contained in a narrow cylindrical glass vessel. The siphon, fitted

with a glass stop-cock in its center, is first filled with water. On opening the stop-cock, diffusion of the salt begins, evidenced by the drawing up of water, as shown by the following figures, for which we are also under obligation to E. Manegold:

Time:	3 days	5 d.	7 d.	9 d.	10 d.
Differences of level:	2.1 mm.	3.5 mm.	4.9 mm.	5.59 mm.	6.7 mm.

However, the effect of diffusion very probably is not only hydrostatic; this brings us to the consideration of a *third* source of energy for the first divisional effect.

It is generally accepted that a dissolved substance, also a diffusing substance, develops an *osmotic pressure*. This osmotic pressure becomes hydrostatically active and measurable, only when the solution meets a mechanical obstacle which hinders the mobility of the dissolved molecules, but not the mobility of the solvent. It is merely another expression of the same fact when we substitute for the term "osmotic pressure," the osmotic attraction of the solvent by the dissolved particles. Ordinarily, the scheme of a semipermeable membrane is selected in demonstrating this tendency of the solvent being attracted by the dissolved molecules; this effect is explained in molecular kinetics by a bombardment of the membrane by the dissolved molecules. It seems, however, that the scheme of a semipermeable membrane is not the only possible method of converting the osmotic pressure into a hydrostatic one, demonstrating the osmotic attraction of liquids. According to the customary

¹ We sincerely thank Dr. Manegold for this friendly suggestion, as well as for others, kindly made.

notion, the dissolved molecules bounce perpendicularly upon the membrane. When the membranes are thick and curved cylindrically, a *slanting*, or even *tangential* impingement of the molecules upon the cylindrical walls of the pores is possible, and has already been the subject of discussion. Also, the well-known experiments of Bartell and Bigelow,¹ E. Cohen² and others, have shown that osmotic effects may be observed, also, in clay cylinders, whose pore-diameters are notably greater than the diameter of the dissolved molecules (osmotic pressure with permeable membranes).³

In pursuing these reflections, we may conclude that in the case of diffusion in a capillary system of the nature of filter paper, the conditions are realized for the manifestation of osmotic effects, *i. e.*, an attraction of the solvent by the salt molecules, here also hindered in their mobility. In such a system, the salt molecules will strike with exceedingly great frequency against the side walls, will thereby suffer a retardation of motion, and thus attract solvent in the same manner as they do in an ordinary osmotic cell. Then we should be dealing here with "Osmosis without membrane," or "Capillary Osmosis." Even in the case when the origin of osmotic pressure is not referred to molecular kinetics, but if, *e. g.*, as H. Hulshof⁴ has done, a "tangential pressure" and an activity of the capillary layer are introduced, based on thermodynamic points of view, a capillary system of the character of filter paper may also be placed in parallel with the usual membrane.

This third explanation of the "first divisional effect" would then be formulated as follows: The impinging of the salt molecules upon the capillary walls of the strip of filter paper causes retardation of the free movement, and consequently of the diffusion of the salt molecules, but not of the movement of the water molecules, which are present in excess. Therefore, an osmotic pressure arises in the direction toward the salt molecules, thus an attraction of the solvent. This osmotic attraction of the solvent would act in the same sense as the two first-named sources of energy, at least as long as there is salt in the lower part of the salt tube. If the salt diffuses further upward, the scene of its osmotic activity would also move upward. We shall shortly discuss this effect more in detail.

To sum up: There are three sources of energy for the "first divisional effect:" (1), A primary hydrostatic pressure, existing at the start of the system; (2), A secondary hydrostatic pressure, caused by diffusion and corresponding increase of weight in the salt tube; (3), Capillary-osmotic pressure, likewise caused by the diffusing salt molecules.

(End of Second Instalment.)

¹ F. E. Bartell, *J. Phys. Chem.*, 16 (1912), 318; Lawrence Bigelow and F. E. Bartell, *J. Am. Chem. Soc.*, 37 (1909), 1194.

² E. Cohen, *Z. physik. Chem.*, 64 (1908), 1.

³ Cf. also the detailed discussions by E. Manegold and Solf, *Kolloid-Z.*, 59 (1932), 179; further literature there given.

⁴ H. Hulshof, *Z. physik. Chem.*, 128 (1927), 110; *Proc. Acad. Amsterdam*, 33 (1930), No. 2.